

General Features

- Positive and negative plates in lead-calcium tin alloy.
- Superior energy density
- Operates at a low internal pressure.
- Gas Recombination.
- Usable in any orientation.
- A recognized component of UL.
- Very high power output.
- Application specific designs.
- Six months shelf life at 20°C.
- Design life 10 years.



Dimensions

	Length	Width	Height	Total Height	Approx.Weight
<i>SI Units</i>	341mm	173mm	283mm	288mm	44.8Kg
<i>English Units</i>	13.4inch	6.81inch	11.1inch	11.3inch	98.7lbs

Performance Characteristics

- Nominal Voltage: 12V
- Number of cell: 6
- Nominal Capacity 77° F(25°C): 15 min Wattage @1.67V 520W/cell
- Nominal Capacity 77° F(25°C): 10 hour rate (13.8A, 10.8V) 138Ah
- Internal Resistance: Fully Charged battery 68° F(20°C) 3.5mΩ
- Self-Discharge: 3% of capacity declined per month at 20°C
- Operating Temperature Range: Discharge -20~60°C Charge -10~60°C Storage -20~60°C
- Max.Discharge Current 68° F(20°C): 1050A (5S)
- Short Circuit Current: 2500A
- Charge Methods: Constant Voltage Charge 68° F(20°C)
 - Cycle use: 14.4 ~ 14.7V Maximum charging current 33.5A
 - Standby use: 13.6 ~ 13.8V

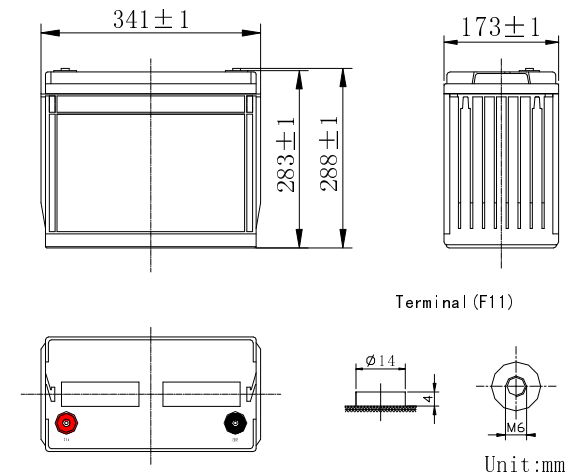



UNH12-520W

Rechargeable Products Sealed Lead Acid Battery

Discharge Date

Constant Current Discharge Date(Amperes at 25°C)																							
End Voltage Per cell/V	10min	15min	20min	25min	30min	35min	40min	45min	50min	55min	1h	1.5h	2h	2.5h	3h	4h	5h	6h	7h	8h	9h	10h	20h
1.60	373	305	255	218	188	169	149	136.5	125	113.5	103	74.5	58.8	50.5	44.0	34.5	28.8	24.0	21.2	18.5	16.9	14.3	7.40
1.65	355	288	243	210	182	160	146	133.5	122	111.5	102	72.8	57.5	49.3	43.1	33.7	28.2	23.5	20.9	18.3	16.7	14.2	7.35
1.70	335	270	230	200	175	155	142	130	119	109	100	71.0	56.0	48.0	42.0	32.8	27.5	23.0	20.5	18.0	16.5	14.1	7.30
1.75	315	252	217	190	168	150	138	126.5	116	106.5	98.0	69.1	54.5	46.7	40.8	31.9	26.8	22.5	20.1	17.7	16.3	14.0	7.25
1.80	293	233	203	178	160	144	132	122	112	103	95.5	66.8	52.8	45.2	39.5	30.8	26.0	21.8	19.6	17.3	16.0	13.8	7.15

Constant Power Discharge Date(Watts per cell at 25°C)																							
End Voltage Per cell/V	10min	15min	20min	25min	30min	35min	40min	45min	50min	55min	1h	1.5h	2h	2.5h	3h	4h	5h	6h	7h	8h	9h	10h	12h
1.60	610	550	430	375	344	307	279	256	235	212	203	146.5	116.5	97.8	86.2	70.3	57.0	50.7	45.3	39.0	36.5	32.1	27.9
1.65	590	530	417	365	334	299	271.5	248.5	228.5	206	197.5	143	114	95.8	84.6	68.8	55.6	49.5	44.4	38.3	35.8	31.7	27.6
1.67	580	520	410	360	330	295	268	245	225	203	195	141.5	113	95.0	84.0	68.0	55.0	49.0	44.0	38.0	35.5	31.5	27.5
1.70	570	505	402	353	324	290	263	240.5	220.5	200	192	139	111	93.7	83.0	67.3	54.1	48.3	43.4	37.5	35.0	31.2	27.3
1.75	545	480	387	341	314	281	254.5	232.5	215	194	187	135	108	91.6	81.4	65.8	52.6	47.1	42.4	36.7	34.2	30.7	27.0
1.80	520	450	370	328	307	271.5	245.5	224	208	188	181	131	105	89.5	79.8	64.3	51.0	45.8	41.3	35.9	33.4	30.1	26.7

